



TRUE UNION SAFETY BLOCK BALL VALVE WITH MOUNTING PADS

NSF certified listing



CH Series

CH100 SOCKET/ CH200 THERAD/ CH300 FLANGED
Size:DN15-DN100

MATERIALS OF CONSTRUCTION

No.	Parts	Pcs	Materials	No.	Parts	Pcs	Materials
1	BODY	1	UPVC , PP , CPVC , PVDF	9	SOLID END O-RING	1	EPDM , VITON
2	BALL	1	UPVC , PP , CPVC , PVDF	10	SEAT	2	TEFLON
3	STEM	1	UPVC , PP , CPVC , PVDF	11	SEAT CARRIER O-RING	1	EPDM , VITON
4	SEAT CARRIER	1	UPVC , PP , CPVC , PVDF	12	BODY O-RING	1	EPDM , VITON
5	END CONNECTOR	2	UPVC , PP , CPVC , PVDF	13	SEAT O-RING	2	EPDM , VITON
6	UNION NUT	2	UPVC , PP , CPVC , PVDF	14	FLANGES	2	UPVC , PP , CPVC , PVDF
7	HANDLE	1	ABS	15	MOUNTING PAD (UP&DOWN)	15A-50A 4 65A-100A 8	BRASS , SUS304
8	SEAT O-RING	15A-50A 2 65A-100A 2	EPDM , VITON				

DIMENSIONS TABLE

Nominal Pipe Size	D1	D2	D3	JIS																	Unit : mm	
				d		e	n	P	L			H	A	B	T	K	E	S	S1	Test press (kgf/cm ²)	Working press (kgf/cm ²)	
				Socket	Thread				Socket	Thread	Flange											
15(1/2")	15	70	95	22	PT 1/2"	15	4	22.2	115	115	153	51	82.7	53.2	15	31	-	4	4	22.5	15	
20(3/4")	19	75	100	26	PT 3/4"	15	4	25.4	126	126	165	63	101.2	63	15	37	-	6	4	22.5	15	
25(1")	25	90	125	32	PT 1"	19	4	28.6	144	144	189	72	111.8	72.2	17	40	-	6	4	22.5	15	
32(1-1/4")	38	100	135	38	PT 1-1/4"	19	4	31.8	181	181	226	86	121.4	97	17	55	-	8	4	22.5	15	
40(1-1/2")	38	105	140	48	PT 1-1/2"	19	4	34.9	181	181	226	86	121.4	97	19	55	-	8	4	22.5	15	
50(2")	48	120	155	60	PT 2"	19	4	38.1	202	202	252	100	149.3	118.9	21	68	-	8	4	22.5	15	
65(2-1/2")	65	140	175	76	PT 2-1/2"	19	4	44.5	227	227	281	140	190	150.1	21	80	41	8	8	15	10	
80(3")	78	150	185	89	PT 3"	19	8	47.6	275	275	330	165.1	230	183.9	22	80	41	8	8	15	10	
100(4")	102	175	210	114	PT 4"	19	8	57.2	321	321	387	172	274	226	22	121	50	8	8	15	10	

Tel: 886-4-2626-6926 Fax: 886-4-2626-7169 Email: shivale8@ms23.hinet.net http://www.shiyu-valve.com.tw

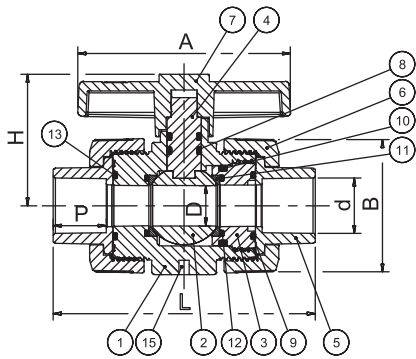

SOCKET & SCREW TYPE

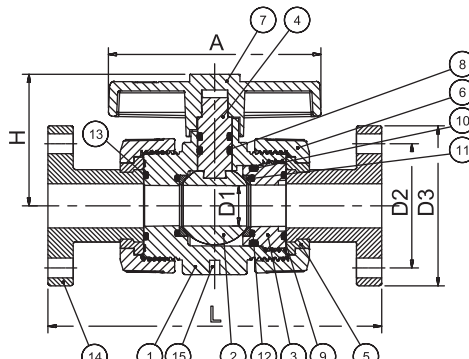

15A ~ 50A FLANGE TYPE

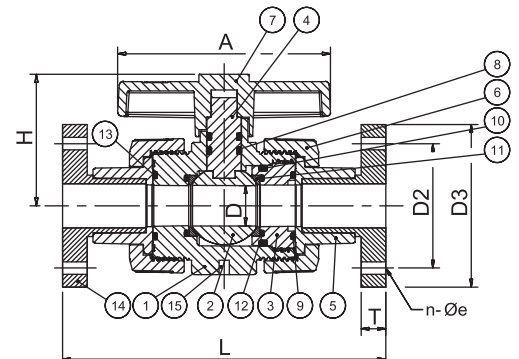

65A ~ 100A FLANGE TYPE

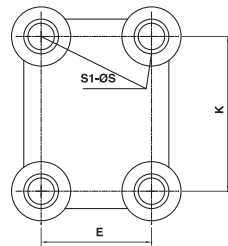

(ON SIZE DN65~DN100)

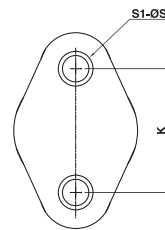

(ON SIZE DN15~DN50)

END VIEW

Bolts inserted pad pattern

DIMENSIONS TABLE

ANSI																					Unit : inch	
Nominal Pipe Size	D1	D2	D3	d		e	n	P	L			H	A	B	T	K	E	S	S1	Test press (kgf/cm ²)	Working press (lb/in ²)	
				Socket	Thread				Socket	Thread	Flange											
15(1/2")	0.59	2.375	3.500	0.848	NPT 1/2"	0.625	4	0.875	4.528	4.528	6.024	2.00	3.25	2.10	0.59	1.22	-	0.157	4	353	235	
20(3/4")	0.748	2.750	3.875	1.058	NPT 3/4"	0.625	4	1.000	4.960	4.960	6.496	2.48	3.98	2.48	0.59	1.45	-	0.236	4	353	235	
25(1")	0.98	3.125	4.250	1.325	NPT 1"	0.625	4	1.125	5.669	5.669	7.440	2.83	4.40	2.84	0.66	1.57	-	0.236	4	353	235	
32(1-1/4")	1.496	3.500	4.625	1.670	NPT 1-1/4"	0.625	4	1.125	7.126	7.126	8.898	3.38	4.78	3.82	0.66	2.16	-	0.315	4	353	235	
40(1-1/2")	1.496	3.875	5.000	1.912	NPT 1-1/2"	0.625	4	1.375	7.126	7.126	8.898	3.38	4.78	3.82	0.75	2.16	-	0.315	4	353	235	
50(2")	1.89	4.750	6.000	2.387	NPT 2"	0.750	4	1.500	7.953	7.953	9.921	3.93	5.88	4.68	0.83	2.67	-	0.315	4	353	235	
65(2-1/2")	2.56	5.500	7.000	2.889	NPT 2-1/2"	0.750	4	1.750	8.937	8.937	11.063	5.51	7.48	5.91	0.83	3.15	1.61	0.315	8	225	150	
80(3")	3.07	6.000	7.500	3.515	NPT 3"	0.750	4	1.750	10.826	10.826	12.992	6.50	9.06	7.24	0.866	3.15	1.61	0.315	8	225	150	
100(4")	4.01	7.500	9.000	4.518	NPT 4"	0.750	8	2.250	12.638	12.638	15.236	6.77	10.97	8.90	0.866	4.76	1.97	0.315	8	225	150	

DIN																					Unit : mm	
Nominal Pipe Size	D1	D2	D3	d		e	n	P	L			H	A	B	T	K	E	S	S1	Test press (bar)	Working press (bar)	
				Socket	Thread				Socket	Thread	Flange											
15(1/2")	15	65	95	20	R 1/2"	14	4	16.0	115	115	153	51	82.7	53.2	15	31	-	4	4	24	16	
20(3/4")	19	75	105	25	R 1/4"	14	4	18.5	126	126	165	63	101.2	63	15	37	-	6	4	24	16	
25(1")	25	85	115	32	R 1"	14	4	22.0	144	144	189	72	111.8	72.2	17	40	-	6	4	24	16	
32(1-1/4")	38	100	140	40	R 1-1/4"	18	4	26.0	181	181	226	86	121.4	97	17	55	-	8	4	24	16	
40(1-1/2")	38	110	150	50	R 1-1/2"	18	4	31.0	181	181	226	86	121.4	97	19	55	-	8	4	24	16	
50(2")	48	125	165	63	R 2"	18	4	37.5	202	202	253	100	149.3	118.9	21	68	-	8	4	24	16	
65(2-1/2")	65	145	185	75	R 2-1/2"	18	4	43.5	227	227	281	140	190	150.1	21	80	41	8	8	15	10	
80(3")	78	160	200	90	R 3"	18	8	51.0	275	275	330	165.1	230.1	183.9	22	80	41	8	8	15	10	
100(4")	102	180	220	110	R 4"	18	8	61.0	321	321	387	172	274	226	22	121	50	8	8	15	10	

The dimension table is calculated based on PVC material.
 ✖ The valve of test pressure is calculated based on PVC PVDF materials.
 The valve of test pressure for PP material is 70% based on the table.
 The flanged length tolerance is according to EN558-1:1995.