

Serial No.	H-V036-E-18
------------	-------------

Butterfly Valve Type 57

Lever Type: 40-200 mm (1 1/2"-8")
 Body Material: PVC, PP, PVDF

Gear Type: 40-350mm (1 1/2"-14")
 Body Material: PVC, PP, PVDF

User's Manual





Contents

(1) Be sure to read the following warranty clauses of our product	1
(2) General operating instructions	2
(3) General instructions for transportation, unpacking and storage	3
(4) Names of parts	4
(5) Working pressure vs. temperature	8
(6) Specification of limit switch	9
(7) Installation procedure	10
(8) Connection of limit switch procedure	14
(9) Operating procedure	15
(10) Disassembly and assembly procedure for parts replacement	17
(11) Installation procedure for handle	19
(12) Adjustment procedure for adjuster on gear type	20
(13) Inspection items	20
(14) Troubleshooting	21
(15) Handling of residual and waste materials	21



ASAHI YUKIZAI CORPORATION

This user's guide contains information important to the proper installation, maintenance and safe use of an ASAHI AV Product. Please store this manual in an easily accessible location.

<Warning & Caution Signs>

 Warning	This symbol reminds the user to take caution due to the potential for serious injury or death.
 Caution	This symbol reminds the user to take caution due to the potential for damage to the valve if used in such a manner.

<Prohibited & Mandatory Action Signs>

	Prohibited: When operating the valve, this symbol indicates an action that should not be taken.
	Mandatory action: When operating the valve, this symbol indicates mandatory actions that must be adhered to.

(1) Be sure to read the following warranty clauses of our product

- Always observe the specifications of and the precautions and instructions on using our product.
- We always strive to improve product quality and reliability, but cannot guarantee perfection. Therefore, should you intend to use this product with any equipment or machinery that may pose the risk of serious or even fatal injury, or property damage, ensure an appropriate safety design or take other measures with sufficient consideration given to possible problems. We shall assume no responsibility for any inconvenience stemming from any action on your part without our written consent in the form of specifications or other documented approval.
- The related technical documents, operation manuals, and other documentation prescribe precautions on selecting, constructing, installing, operating, maintaining, and servicing our products. For details, consult with our nearest distributor or agent.
- Our product warranty extends for one and a half years after the product is shipped from our factory or one year after the product is installed, whichever comes first. Any product abnormality that occurs during the warranty period or which is reported to us will be investigated immediately to identify its cause. Should our product be deemed defective, we shall assume the responsibility to repair or replace it free of charge.
- Any repair or replacement needed after the warranty period ends shall be charged to the customer.
- The warranty does not cover the following cases:
 - (1) Using our product under any condition not covered by our defined scope of warranty.
 - (2) Failure to observe our defined precautions or instructions regarding the construction, installation, handling, maintenance, or servicing of our product.
 - (3) Any inconvenience caused by any product other than ours.
 - (4) Remodeling or otherwise modifying our product by anyone other than us.
 - (5) Using any part of our product for anything other than the intended use of the product.
 - (6) Any abnormality that occurs due to a natural disaster, accident, or other incident not stemming from something inside our product.

(2) General operating instructions



Warning

- Using a positive-pressure gas with our plastic piping may pose a dangerous condition due to the repellent force particular to compressible fluids even when the gas is under similar pressures used for liquids. Therefore, be sure to take the necessary safety precautions such as covering the piping with protective material. For inquiries, please contact us. For conducting a leak test on newly installed piping, be sure to check for leaks under water pressure. If absolutely necessary to use a gas in testing, please consult your nearest service station beforehand.



Caution

- Do not step on or apply excessive weight on valve. (It can be damaged.)

- Do not use the valve in conditions where the fluid may have crystallized.

(The valve will not operate properly.)



- Keep the valve away from excessive heat or fire. (It can be damaged, or destroyed.)

- Always operate the valve within the pressure vs. temperature range.

(The valve can be damaged or deformed by operating beyond the allowable range.)

- Allow sufficient space for maintenance and inspection.

- Select a valve material that is compatible with the media. For chemical resistance information, refer to “CHEMICAL RESISTANCE ON ASAHI AV VALVE”.

(Some chemicals may damage incompatible valve materials.)

- Keep the valve out of direct sunlight, water and dust. Use cover to shield the valve.

(The valve will not operate properly.)

- Perform periodic maintenance. (Leakage may develop due to temperature changes or periods of prolonged storage, rest, or operation.)

- Gear Operator Operation; we utilize a self-locking worm gear design on our manual operators.

This design allows flow control of the valve in intermediate positions in normal process conditions. In applications where very high velocity, turbulence flow or vibration is present and an intermediate setting is required, it is recommended to install a locking device.

The locking device will prevent the possibility of the valve drifting in severe condition from its original intermediate setting.



Handle lock



- In the case of high temperature fluids, if there is a misalignment between the center of the valve and the flanges, it will damage the seat. Take care in their installation.

- Please be sure to use Chambered Stub Flanges for installation of DN150 ASAHI AV BUTTERFLY VALVES in stub flanges d180 SDR21 and bigger SDR of piping.

(3) General instructions for transportation, unpacking and storage

- 
Warning
 - When suspending and supporting a valve, take care and do not stand under a suspended valve.
- 
Caution
 - This valve is not designed to handle impacts of any kind. Avoid throwing or dropping the valve.
 - Avoid scratching the valve with any sharp object.
 - Do not over-stack cardboard shipping boxes. Excessively stacked packages may collapse.
 - Avoid contact with any coal tar creosote, insecticides, vermicides or paint.
(These chemicals may cause damage to the valve.)
 - When transporting a valve, do not carry it by the handle.
- 
 - Store products in their corrugated cardboard boxes. Avoid exposing products to direct sunlight, and store them indoors (at room temperature). Also avoid storing products in areas with excessive temperatures. (Corrugated cardboard packages become weaker as they become wet with water or other liquid. Take care in storage and handling.)
 - After unpacking the products, check that they are defect-free and meet the specifications.

(4) Names of parts

Type 57 (Lever / Gear Type): 40-350mm (1 1/2"-14")

Body Material: PVC, PP, PVDF

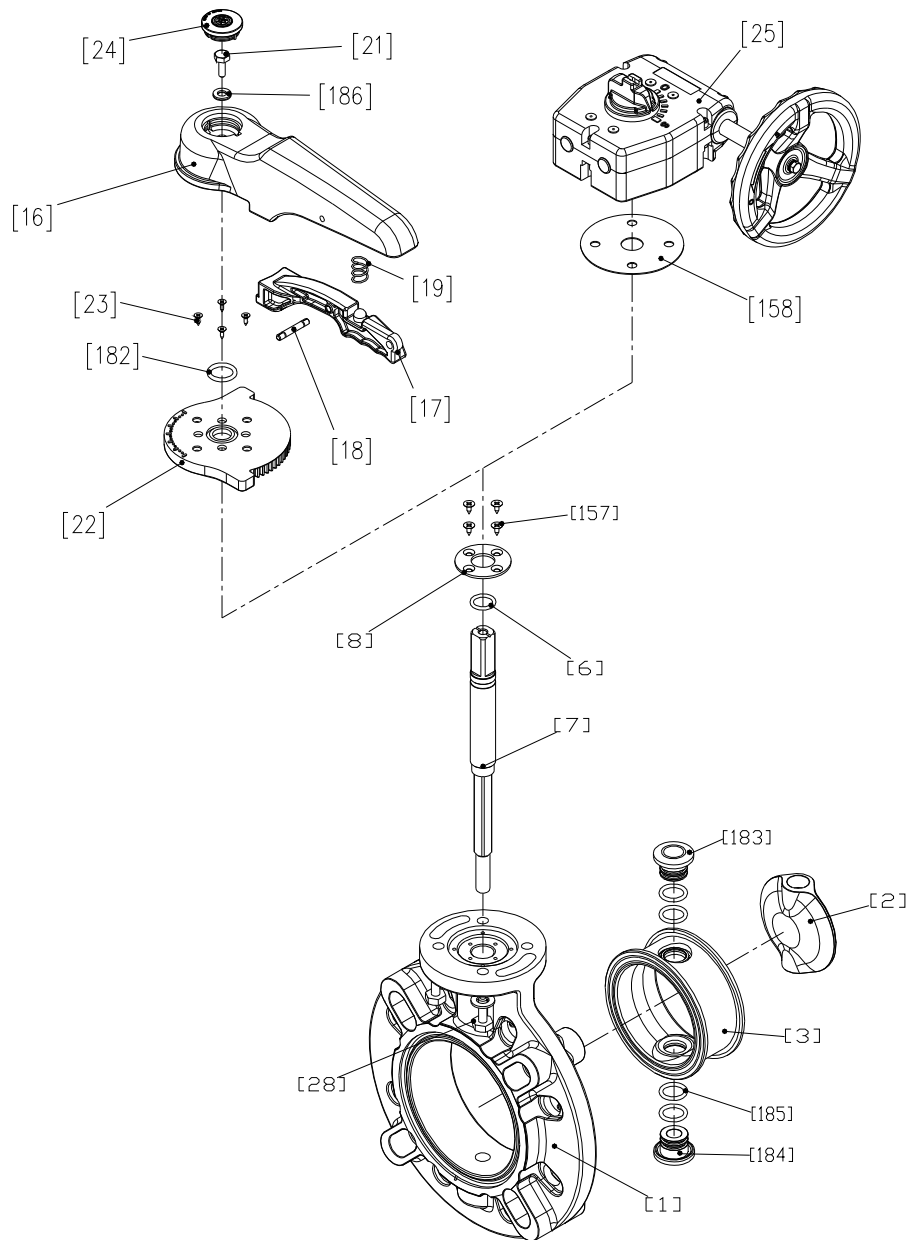

No.	Description	No.	Description	No.	Description
[1]	Body	[18]	Pin	[157]	Screw (F)
[2]	Disc	[19]	Spring	[158]	Gasket (L)
[3]	Seat	[21]	Bolt (A)	[182]	O-Ring (H)
[6]	O-Ring (C)	[22]	Locking Plate	[183]	Seat Bush (A)
[7]	Stem	[23]	Screw (B)	[184]	Seat Bush (B)
[8]	Stem Holder (A)	[24]	Cap (A)	[185]	O-Ring (I)
[16]	Handle (A)	[25]	Gear Box	[186]	Rubber + Washer
[17]	Handle Lever	[28]	Bolt (C)		

Type 57 (Top Gear Type): 40-350mm (1 1/2"-14")

Body Material: PVC, PP, PVDF

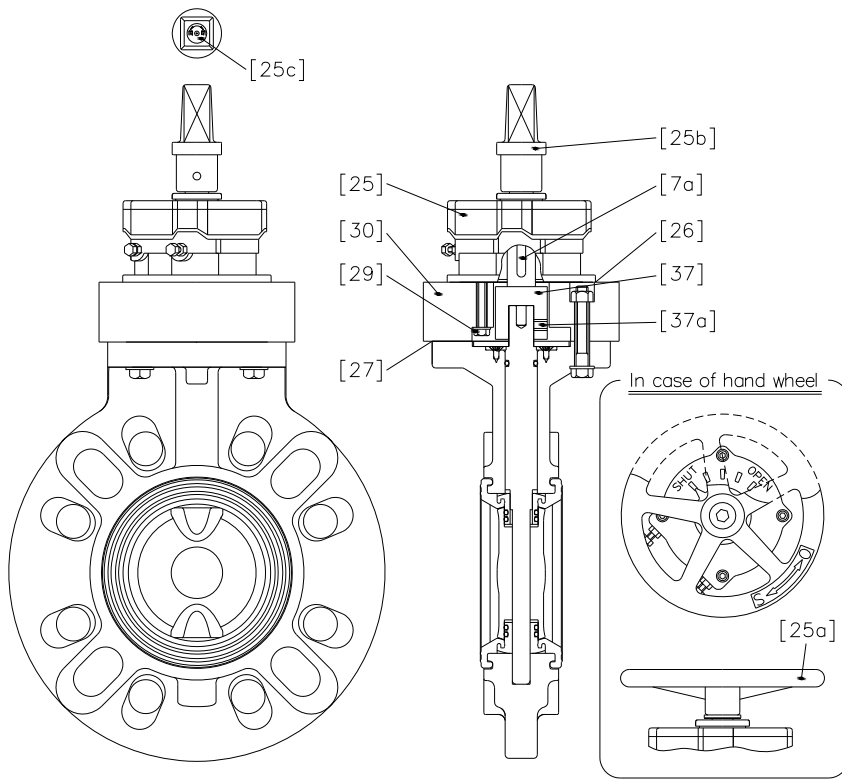

No.	Description
[7a]	Key (A)
[25]	Gear Box
[25a]	Hand Wheel
[25b]	Cap (B)
[25c]	Indicator Board
[26]	Gasket (A)
[27]	Gasket (B)
[29]	Bolt (D)
[30]	Stand
[37]	Joint (A)
[37a]	Screw (C)

Type 57 (Gear Type): 40-350mm (1 1/2"-14") with Handle Lock (Option)

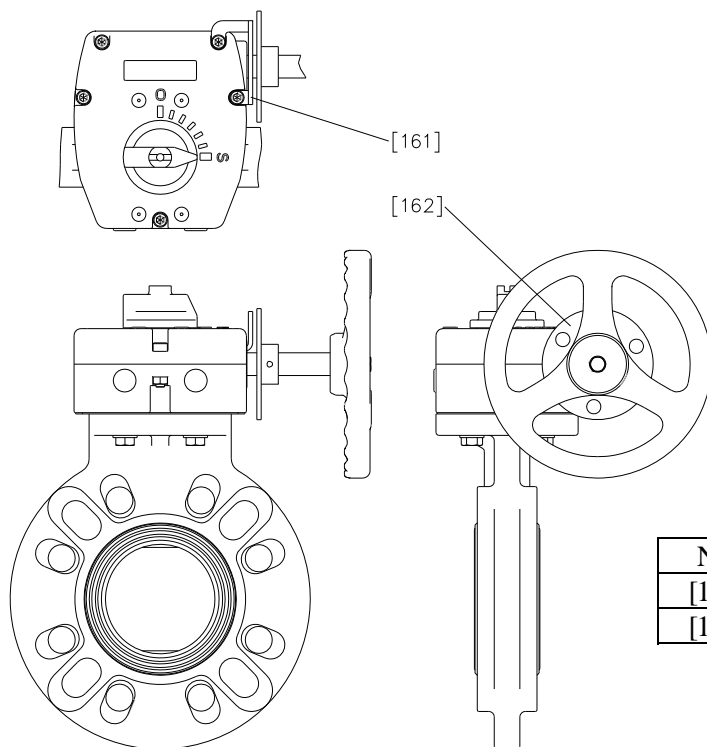

No.	Description
[161]	Lock Plate (A)
[162]	Lock Plate (B)

Type 57 (Chain Type): 40-350mm (1 1/2"-14") (Option)

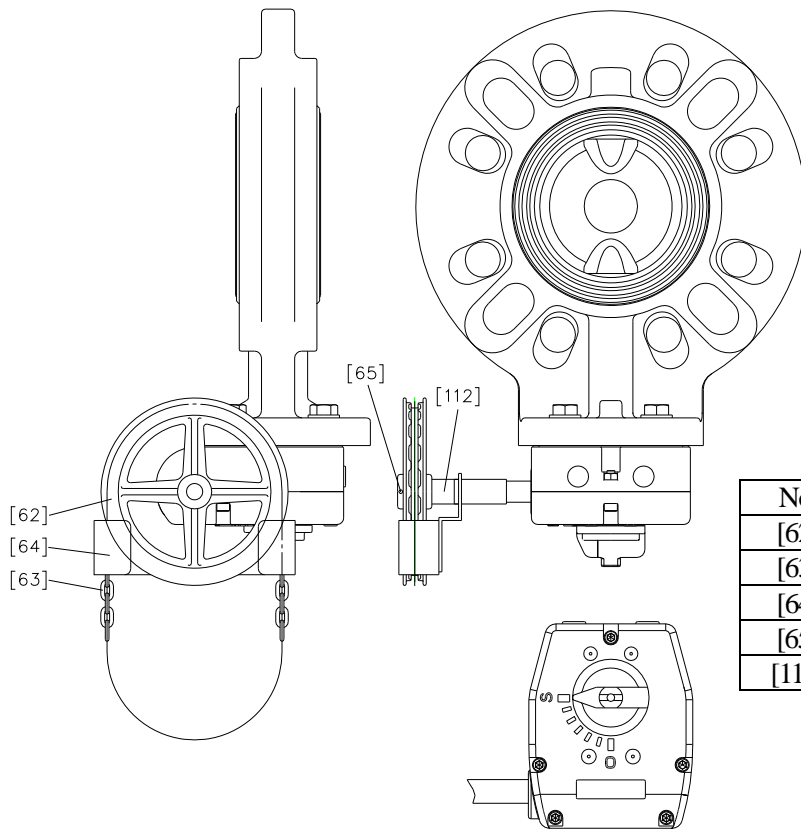

No.	Description
[62]	Sprocket Wheel
[63]	Chain (A)
[64]	Chain Cover
[65]	Set Pin
[112]	Joint (B)

Type 57 (Long Stem Type): 40-350mm (1 1/2"-14") (Option)

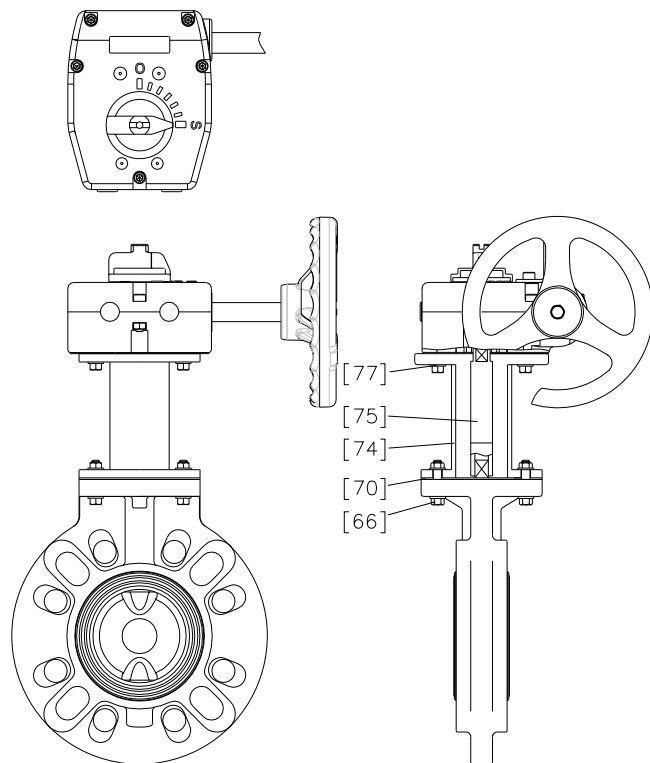

No.	Description
[66]	Bolt+Nut (B)
[70]	Gasket (C)
[74]	Pipe
[75]	Shaft
[77]	Bolt (H)

Type 57 (Lever Type): 40-350mm (1 1/2"-14") with Limit Switch (1LS1--J) (Option)

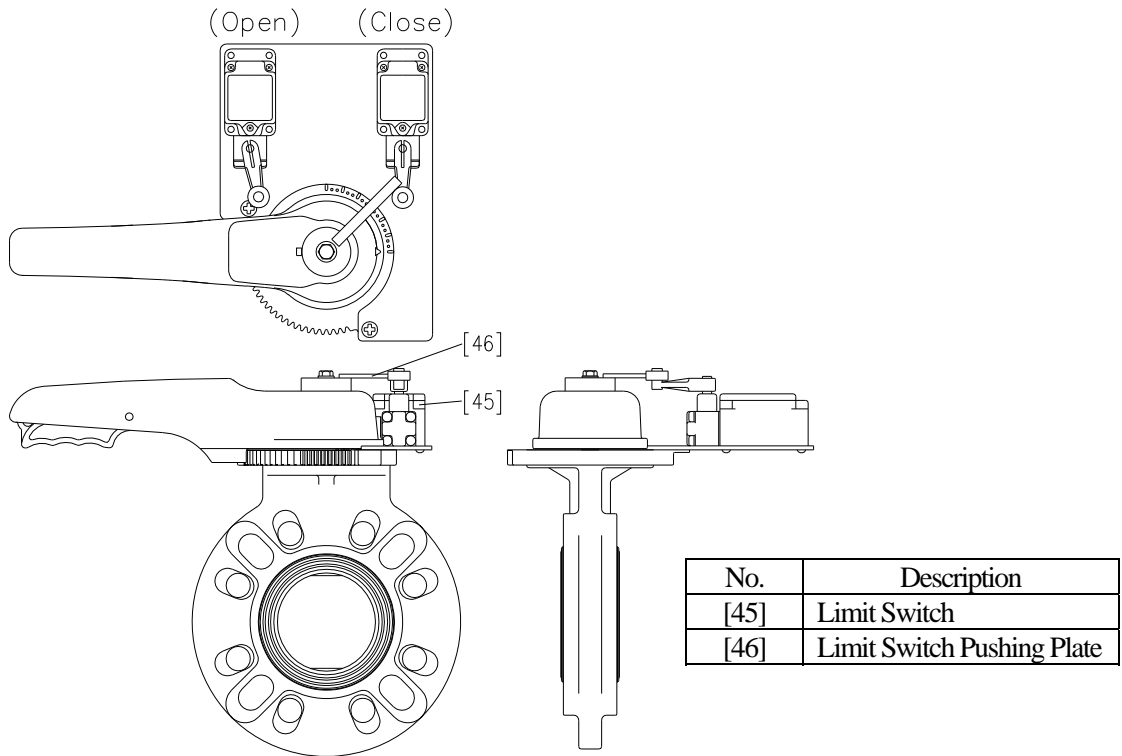

Type 57 (Gear Type): 40-350mm (1 1/2"-14") with Limit Switch Box (TA2-SB2/ TA-200-SB2) (Option)

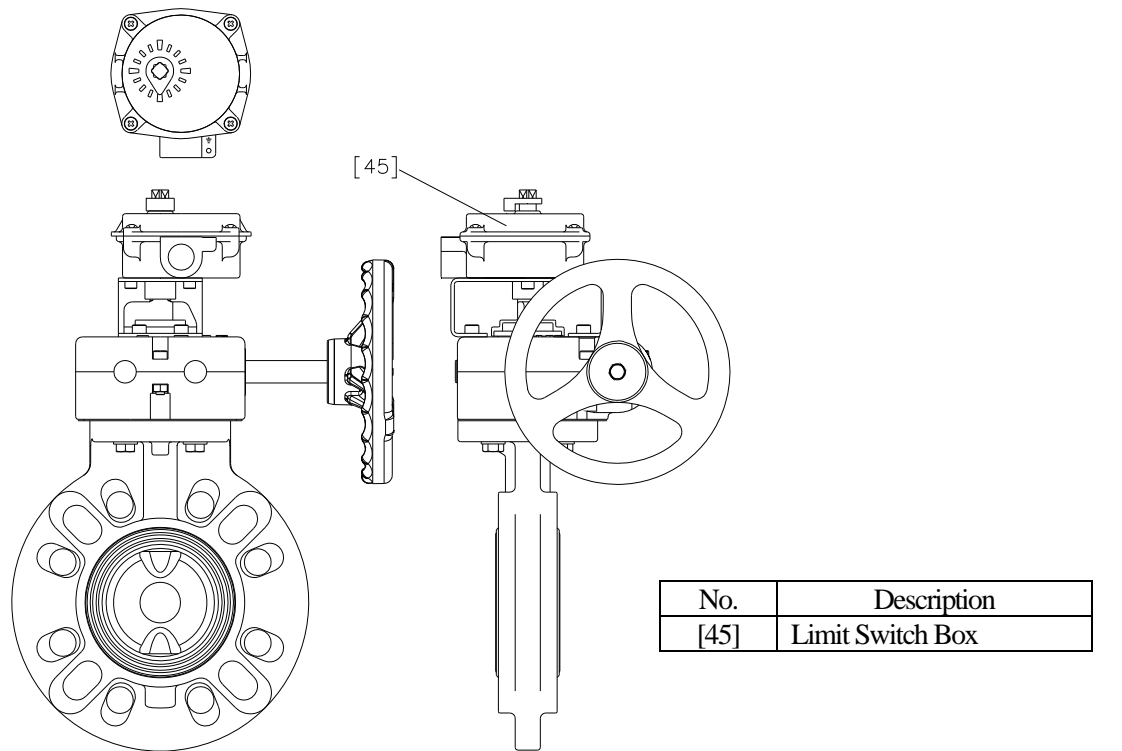

(5) Working pressure vs. temperature

BUTTERFLY VALVE TYPE57

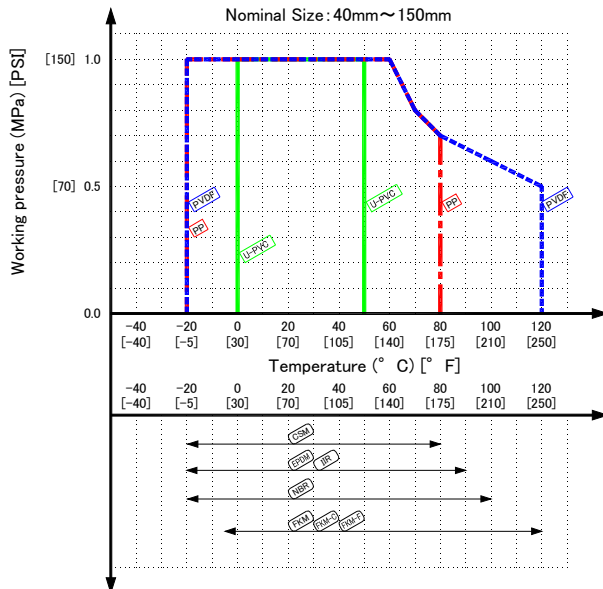

BUTTERFLY VALVE TYPE57

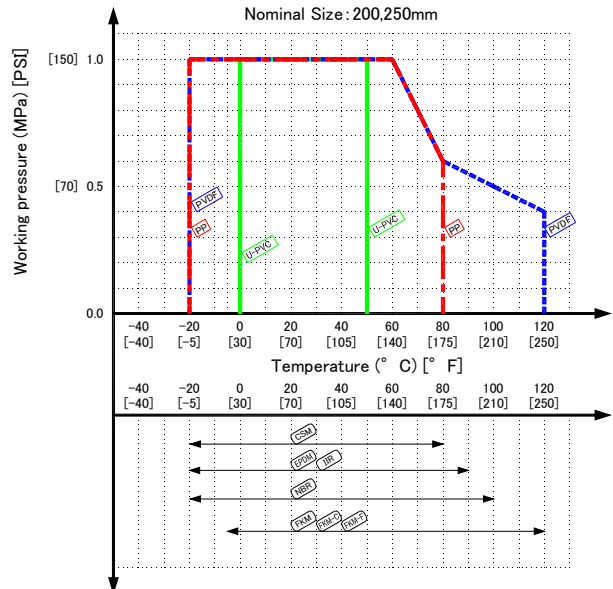

BUTTERFLY VALVE TYPE57

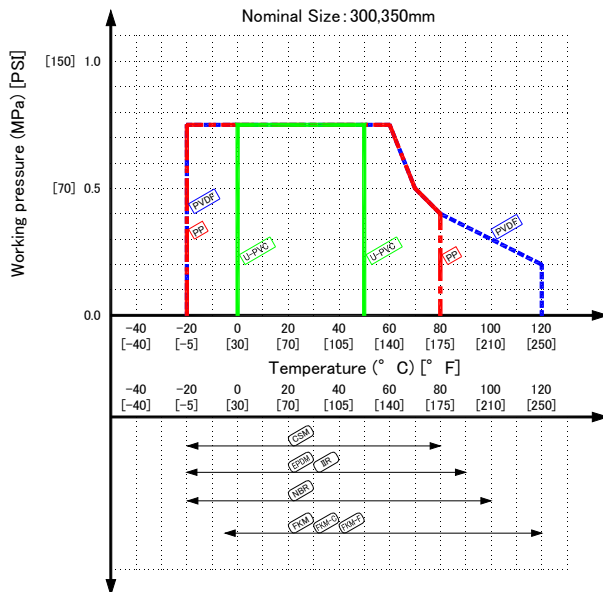

(6) Specification of limit switch (option)

Nominal Size	Type	Type Code	Protection Grade
40-200mm (1 1/2"-8")	Lever Type	1LS1-J	IP67
40-300mm (1 1/2"-12")	Gear Type	TA2-SB2	IP65
350mm (14")	Gear Type	TA-200-SB2	IP55

Limit Switch Rating

Type Code	Rate Voltage (V)	Resistive Load (A)	Inductive Load (A)
1LS1-J	AC125	10	6
	AC250	10	6
	DC115	0.8	0.2
	DC230	0.4	0.1
TA2-SB2	AC125	11	7
	AC250	11	7
	DC125	0.5	-
	DC250	0.25	-
TA-200-SB2	AC125	11	7
	AC250	11	7
	DC125	0.5	0.1
	DC250	0.25	0.04

Connection Diagram (At intermediate opening)

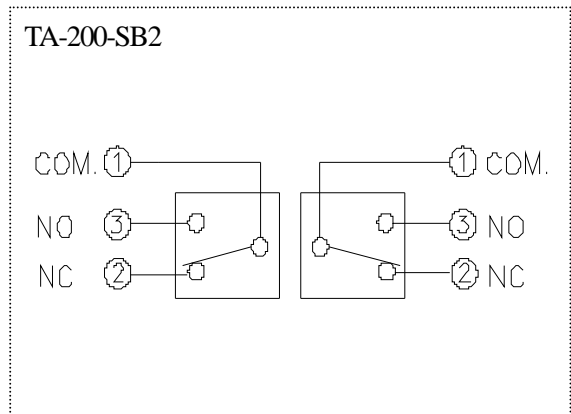
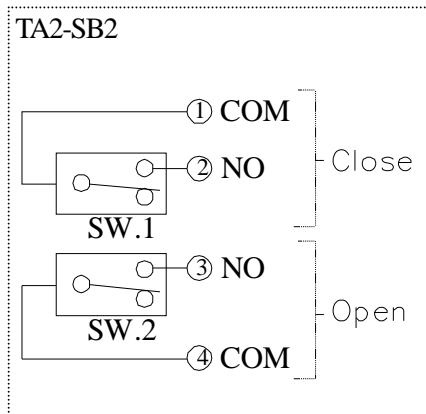
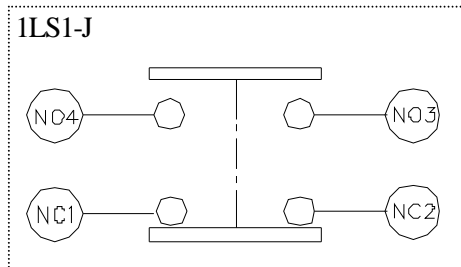

(7) Installation procedure

 - When suspending and supporting a valve, take care and do not stand under a suspended valve.

Warning

-  - Be sure to conduct a safety check on all hand and power tools to be used before beginning work.
- Wear protective gloves and safety goggles as fluid remain in the valve even if the pipeline is empty. (You may be injured.)

 - When installing a pipe support by means of a U-band or something similar, take care not to over-tighten. (Excessive force may damage the pipe.)

Caution

- When installing pipes and valves, ensure that they are not subjected to tension, compression, bending, impact, or other excessive stress.
- Do not install the valve with the disc fully closed. (The disc may pinch into the seat, resulting in a high operating torque and preventing the valve from operating properly.)

-  - Use flat faced flanges for connection to AV Valves.
- Ensure that the mating flanges are of the same standards.
- The gasket is unnecessary. (The seat carries out the role of the gasket.)

- The valve disc is in the position indicated by solid lines in figure to the right prior to shipment from the factory. If the valve is opened or closed after unpacking, it must be reset in this position before installation. Failure to do so will result in damage to the surface of the valve seat during handling and installation.

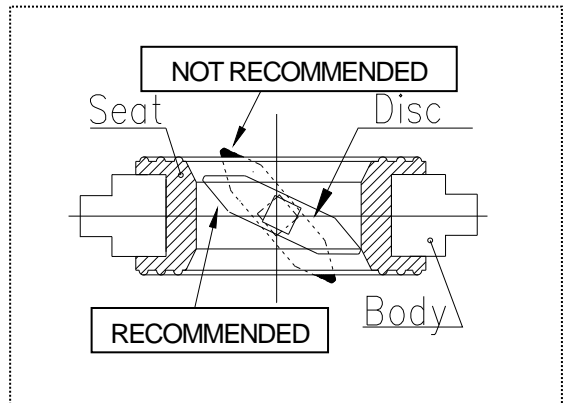

- Care must be used during piping installation to ensure that the pipes or flanges are properly aligned so that the valve disc does not contact them in any setting. Misalignment as in figure below will result in damage to the valve.

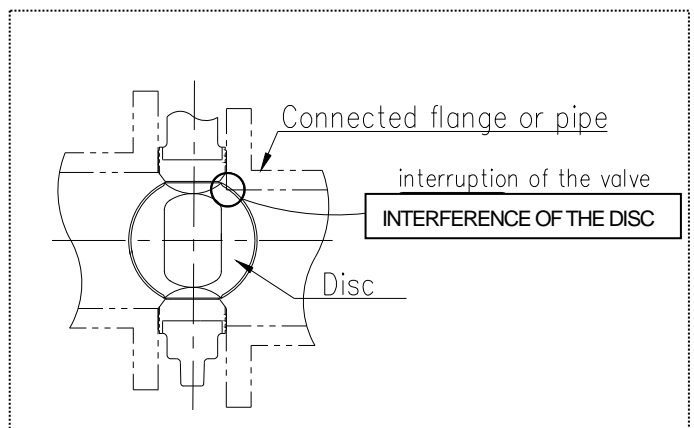

In case of an abutting thick walled flange and pipe, shave the flange or the pipe inner diameter in order to avoid contact of pipe and disc. If the inside diameter of the connecting pipe is larger than dimension D below, shaving is not necessary.

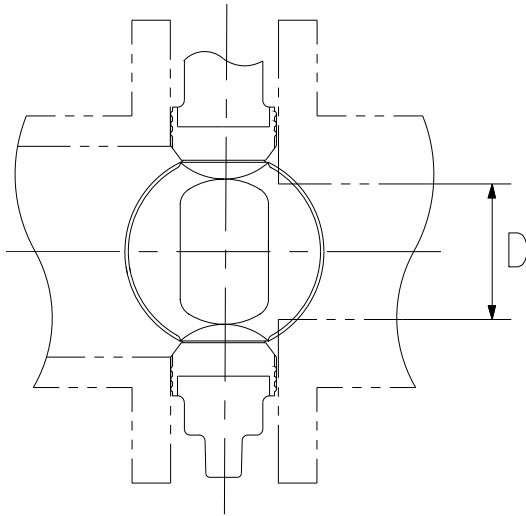

Unit: mm (inch)

Nominal Size	Diameter D
40mm (1 1/2")	31mm (1.22")
50mm (2")	43mm (1.69")
65mm (2 1/2")	57mm (2.24")
80mm (3")	67mm (2.64")
100mm (4")	91mm (3.58")
125mm (5")	115mm (4.53")
150mm (6")	137mm (5.39")
200mm (8")	179mm (7.05")
250mm (10")	231mm (9.09")
300mm (12")	280mm (11.02")
350mm (14")	333mm (13.11")

Necessary items

- Torque Wrench
- Spanner Wrench

Procedure

- 1) Install the valve between flanges and open the valve slightly.
 *The disc [2] is prevented from overflowing. (The disc [2] is damaged.)
- 2) Insert bolts, set nuts and washer and tighten the bolts and nuts temporarily by hand.

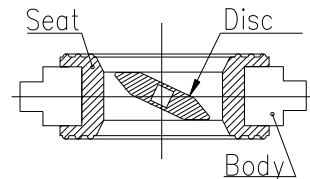

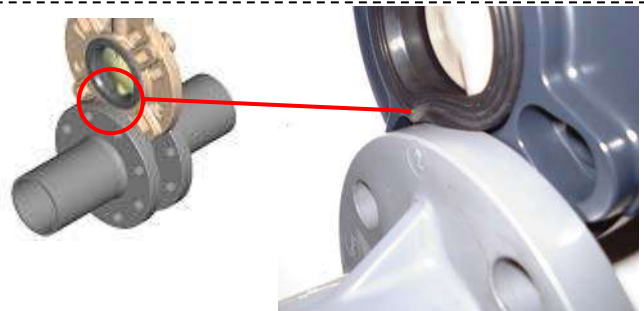

Caution

- When you insert a valve between flanges, please insert after extending the fields of flanges fully. (If you insert a valve by force without fully extending fields of flanges, a liner may be turned over and suffer a crack.)



The parallelism and axial misalignment of the flange surface should be under the values shown in the following table



  - The parallelism and axial misalignment of the flange surface should be under the values shown in the following table to prevent damage the valve. (A failure to observe them can cause destruction due to stress application to the pipe)

Unit : mm (inch)

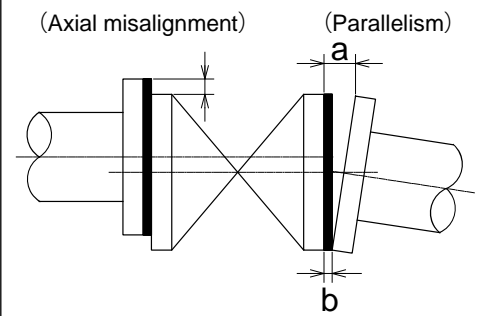
Nom. Size	Axial Misalignment	Parallelism (a-b)
40 - 80mm (1 1/2"-3")	1.0 (0.04)	0.8 (0.03)
100-150mm (4"-6")	1.0 (0.04)	1.0 (0.04)
200-350mm (8"-14")	1.5 (0.06)	1.0 (0.04)



- 3) Tighten the bolts and nuts gradually with torque wrench to the specified torque in a diagonal manner.
- 4) Tighten it more than 2 turns clockwise with specified torque.

  - Do not tighten at the specified torque or more.
(The valve can be damaged or leak.)

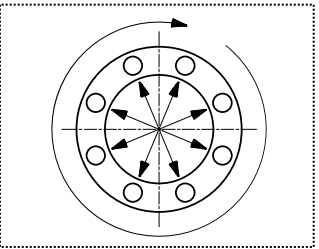

Recommended torque value

Unit: N·m {kgf·cm} [lb·inch]

Nom. Size	40mm (1 1/2")	50, 65mm (2", 2 1/2")	80, 100 mm (3", 4")
Torque value	20.0 {204} [177]	22.5 {230} [200]	30.0 {306} [266]

Nom. Size	125, 150 mm (5", 6")	200, 250 mm (8", 10")	300, 350 mm (12", 14")
Torque value	40.0 {408} [355]	55.0 {561} [488]	60.0 {612} [532]

Caution : Avoid excessive tightening. (The valve can be damaged.)

<JIS Standard>

Body Material: PVC, PP, PVDF

Dimension of Insert Bolt

Nom. Size		Bolt (Minimum)			Nut	Washer
mm	inch	d	L	S		
40	1 1/2"	M16	125mm (4.92")	35mm (1.38")	M16	16mm (0.63")
50	2"		125mm (4.92")			
65	2 1/2"		130mm (5.12")			
80	3"		130mm (5.12")			
100	4"		145mm (5.71")			
125	5"	M20	165mm (6.50")	40mm (1.57")	M20	20mm (0.79")
150	6"		175mm (6.89")			
200	8"		190mm (7.48")			
250	10"	M22	220mm (8.66")	40mm (1.57")	M22	22mm (0.87")
300	12"		245mm (9.65")			
350	14"		250mm (9.82")			

<ANSI Standard>



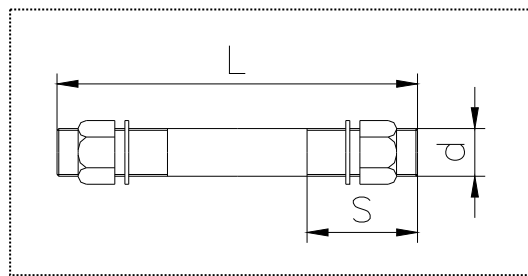

Body Material: PVC, PP, PVDF

Dimension of Insert Bolt

Nom. Size		Bolt (Minimum)			Nut	Washer
mm	inch	d	L	S		
40	1 1/2"	5/8"-11	125mm (4.92")	35mm (1.38")	5/8"-11	5/8" Flat (0.63")
50	2"		125mm (4.92")			
65	2 1/2"		130mm (5.12")			
80	3"		130mm (5.12")			
100	4"		145mm (5.71")			
125	5"	3/4"-10	165mm (6.50")	40mm (1.57")	3/4"-10	3/4" Flat (0.79")
150	6"		175mm (6.89")			
200	8"		190mm (7.48")			
250	10"	7/8"-9	220mm (8.66")	40mm (1.57")	7/8"-9	7/8" Flat (0.87")
300	12"		245mm (9.65")			
350	14"		250mm (9.82")			



(8) Connection of limit switch procedure (option)

- Warning**   - Shut down the power on the equipment before connecting wires. There are risks of electrical shock depending on the level of operating voltage.
- Caution**   - Be sure that the terminal cover and body cover are put on during the operation.
- Caution** - If you use the limit switch at 1mA-100mA or 5-30V, consult near Asahi dealer.

- Necessary items**
- Screw driver (+)
 - Wire stripper
 - Connector (G1/2)
 - Terminal crimping tool
 - Crimp-style terminal

Procedure (1LS1-J)

- 1) Loosen the three screws used to attach the limit switch cover with a screwdriver (+) and remove the cover from the limit switch.
*These screws are captive.
- 2) Pull and remove the protective cap, made of resin, from the cover.
- 3) Draw the cable through the connector.
- 4) Strip the cable with a wire stripper.
- 5) Install a crimp-style terminal on the lead wire with a terminal crimping tool.
- 6) Connect the terminal screw with a screwdriver (+) according to the internal circuit diagram show in page 9.
* Tighten the screws. (If not, electric leaks or shocks may occur.)
- 7) Tighten the above three screws with a screw driver (+) to install the cover on the limit switch.
- 8) Tighten the cable by connector.

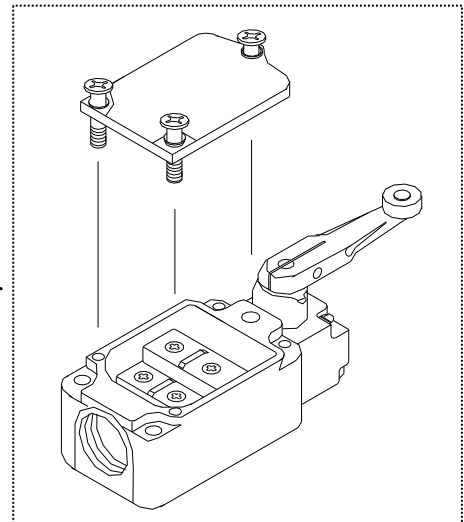

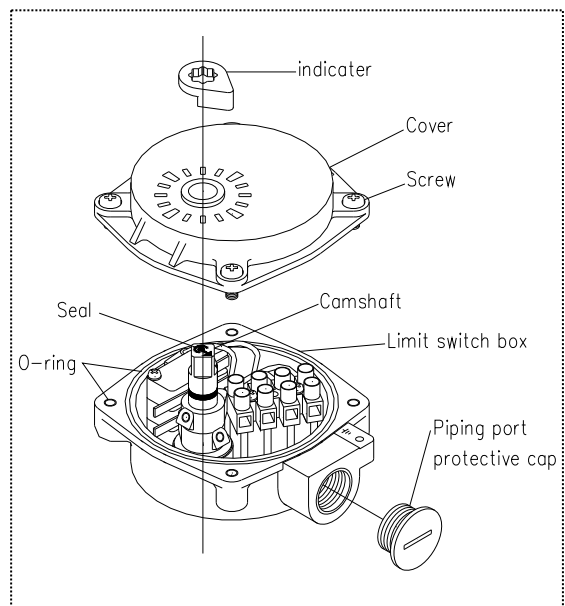

Procedure (TA2-SB2/ TA-200-SB2)

- 1) Remove the indicator.
- 2) Remove the fixed screws from casing using screw driver (+).
※Don't be missing the o-ring of case end.
- 3) Turn to counter clockwise and remove the piping port protective cap.
- 4) Draw the cable through the connector.
- 5) Strip the cable with wire stripper.
- 6) Connect the cable to terminal board with a screw driver (-) in accordance page 9.
※Tighten the screws. (Short circuit or shocks may occur.)
- 7) Tighten up the connector to fix the cable.
- 8) The screws must be tightened in turn after set the casing with screws driver (+)



- 9) Inset the indicator to the upper camshaft which must be set same direction of the seal's arrow.
※Be sure to set the o-ring when the casing is re-set. (Short circuit or shocks may occur.)

(9) Operating procedure

  - Do not use the valve to fluid containing slurry. (The valve will not operate properly.)

Caution

 - The installed valve must never be opened or closed when foreign matter such as sand is present in the pipeline.

- Do not exert excessive force in closing the valve.
- When operating the handle, be sure to do so with your hand. (Using a tool may damage the handle.)

- 1) Open and close the valve by turning handle smoothly. (Turn clockwise to close and counterclockwise to open.)
- 2) In case of lever type (40-200 mm { 1 1/2''-8''}), the direction of handle is same as the disc as shown in Fig. 9-1.
 - For the full-shut (Close) position, the handle is perpendicular to the piping axis direction.
 - For the full-opened position, the handle is parallel to the piping axis direction.

Full-Shut (Close) Position Full-Open Position

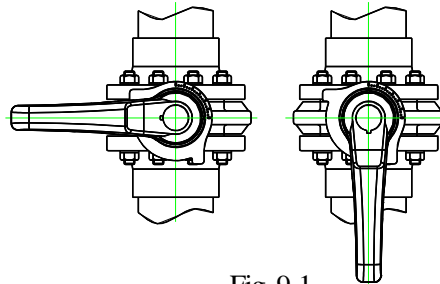

Fig. 9-1

- 3) In case of gear type (40-350 mm { 1 1/2''-14''}), the indicator shows the position of the disc on the top of gear box. (Fig.9-2, Fig.9-3)
 - For the full-shut (close) position, the indication shows Shut (S).
 - For the full-opened position, the indication shows Open (O).

Full-Shut (Close) Position

Full-Open Position

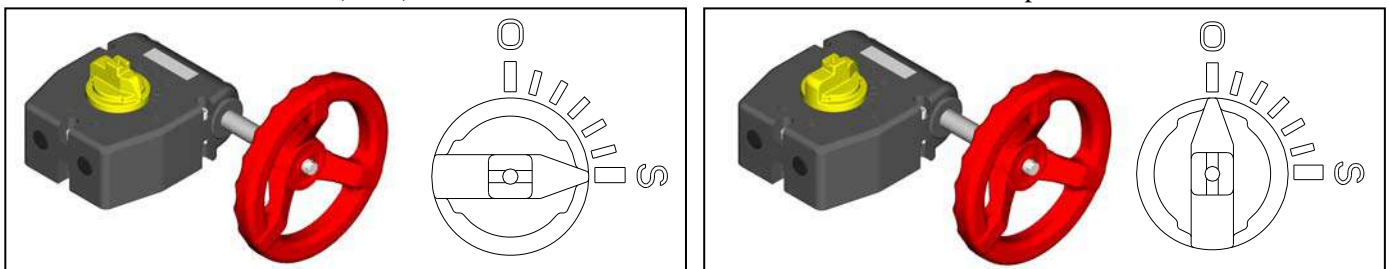

Fig.9-2

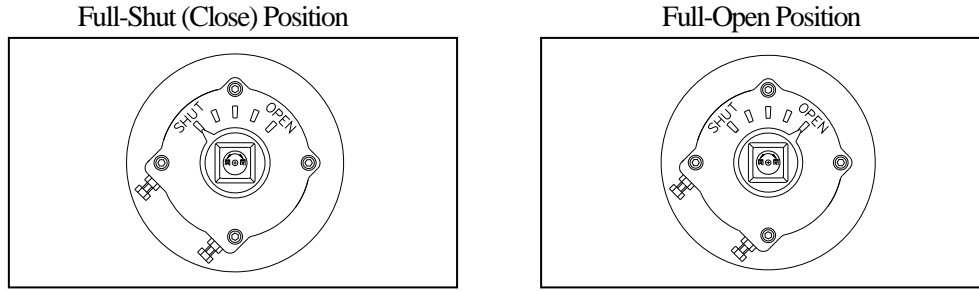

Fig.9-3

  - The adjustments for full-opened and full-shut position are step-less, and it can be done with the adjuster.
Caution

Technical Data for Operation



Nominal Size mm (inch)	Stem Torque (N·m)	Length of Lever and Diameter of Handle (mm)			Required Operating Force (N)			
		Seal	Lever Type	Gear Type	Top Gear Type	Lever Type	Gear Type	Top Gear Type
40mm (1 1/2")	5.0		220	160	140	23	3	4
50mm (2")	10		220	160	140	46	5	8
65mm (2 1/2")	15		220	160	140	68	8	11
80mm (3")	20		250	160	140	80	11	15
100mm (4")	30		250	160	140	120	16	22
125mm (5")	40		320	160	200	125	21	20
150mm (6")	65		320	160	200	205	34	33
200mm (8")	165		400	160	200	395	87	83
250mm (10")	300		-	160	200	-	158	125
300mm (12")	330		-	300	250	-	74	83
350mm (14")	400		-	300	250	-	90	100

Note : Data mentioned in the table above is reference only.

These data are measured in standard condition and it slightly differs depending on conditions.

Required Operating Force is the data by turning handle with both hands.

(10) Disassembly and assembly procedure for parts replacement

- Warning**  - The handle part can be removed with line pressure present. The stem retainer can't be removed with line pressure present. If stem retainer needs to be removed, there can not be line pressure present.
- Caution**  - Wear protective gloves and safety goggles as fluid remain in the valve even if the pipeline is empty. (You may be injured.)
- When installing pipes and valves, ensure that they are not subjected to tension, compression, bending, impact, or other excessive stress.
 - Do not change or replace valve parts under line pressure.

- Necessary items**
- Protective Gloves
 - Vise
 - Circular Stick (Plastic or Wood)
 - Goggles
 - Grease (Silicone)
 - Pressing Machine
 - Screwdriver (+)
 - Spanner Wrench
 - Square Lumber
 - Hammer
 - Screwdriver (-)

<< **Disassembly** >>

Procedure

- 1) Drain fluid completely from the pipeline.
- 2) Leave the valve slightly opened.
- 3) Loosen the connecting bolts and nuts.
- 4) Remove the valve from the pipeline.

Lever Type <Nominal size 40-200mm (1 1/2"-8")

- 5) To remove handle [16], first take off the cap [24] by using screw driver (-) and release bolt [21] by using socket wrench, then pull up the handle [16] while holding handle lever [17].
- 6) To take off locking plate [22], release 4 self-tapping screws [23] by using screw driver (+) and take off stem holder [8].

Gear Type <Nominal size 40-350mm (1 1/2"-14")

- 5) Loosen set bolt [28] for gear box [25] and pull off the gear box upward with gasket [158]*.
- 6) Remove the stem holder [8]. Release 4 tapping screws [157] by using screw driver (+).

Lever & Gear Type

- 7) Hold flat surface of Stem [7] with vise and pull off valve body [1].
- 8) Insert the screw driver (-) between body [1] and seat [3]. Disc [2] and seat [3] are extruded by using screw driver (-).
- 9) Remove the disc [2], seat bush (A) [183] and seat bush (B) [184] from the seat [3].
- 10) Remove the O-ring (C) [6] from the stem [7].

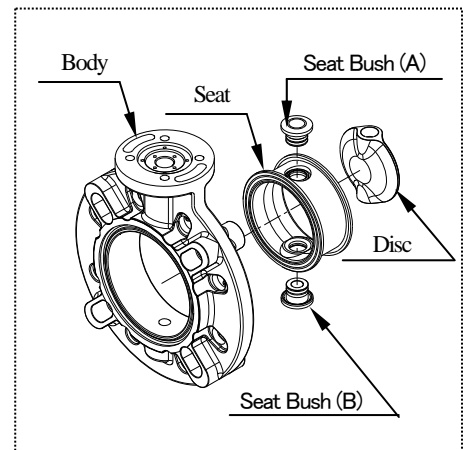

<< Assembly >>

Procedure

- 1) Before starting assembly, grease (Silicone) should be spread on the O-ring (C) [6] and O-ring (I) [185].
- 2) Put the O-ring (C) [6] onto the stem [7]. Put the O-ring (I) [185] onto the stem bush (A) [183] and B [184].
- 3) Grease (Silicone) should be spread on the top and bottom disc [2], the stem of the seat [3].
- 4) Put the disc [2], seat bush (A) [183] and seat bush (B) [184] onto the seat [3]. "The set of seat - disc" call for combined parts.
- 5) Put it into the state of open the valve slightly. Insert the set of seat - disc [3] into the body [1].

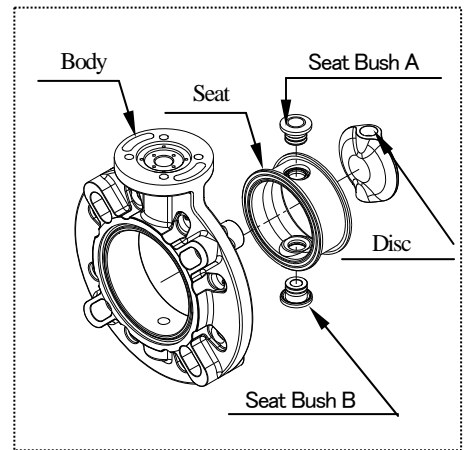

Caution

- Make certain stem hole of seat are properly aligned. The upper side stem hole of seat bush (A) [183] has larger than seat bush (B) [184] of lower side. When the stem bush is assembled oppositely, the stem [7] cannot be inserted.

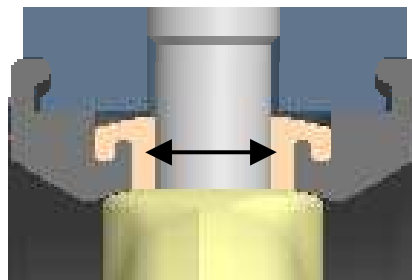
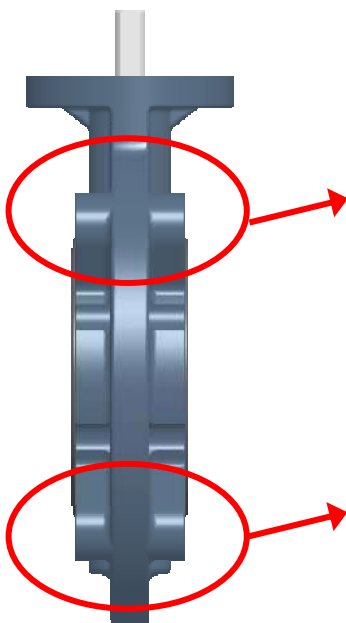

Upper side:
Stem hole is large size

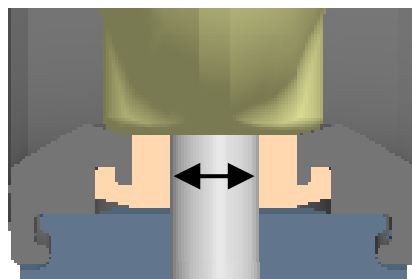

Lower side:
Stem hole is small size

- Make certain tabs are properly aligned.

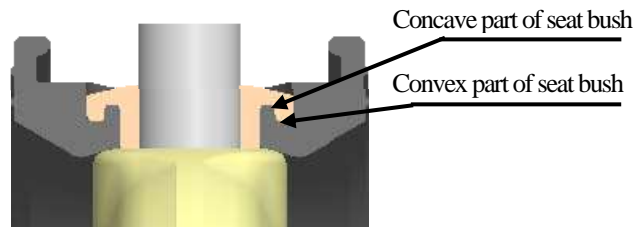

- 6) Insert the stem [7] of the body [1].
- 7) Install stem holder [8] onto valve body [1] with countersunk holes facing up using 4 screws [157].
- 8) To install lever or gear operator reverse disassembly procedure #5).
 - * Make certain line scribed on top of stem [7] indicates disc [2] position while installing stem [7].
- 9) After assembly, make sure that the valve can be fully opened and closed smoothly.

(11) Installation procedure for handle

- Necessary items
- Plastic Hammer ● Socket Wrench ● Screw Driver(-)
 - Goggles ● Protective Glove

《Installation》

Procedure

- 1) Install the handle on the stem. Set the direction of handle in the indication line at the top of stem.
- 2) Fix the handle at the top of stem with the attached bolts and washer by using socket wrench.
- 3) Set the convex part at the side of the cap and the concave of the handle, and set in the cap by striking lightly by using a plastic hammer.

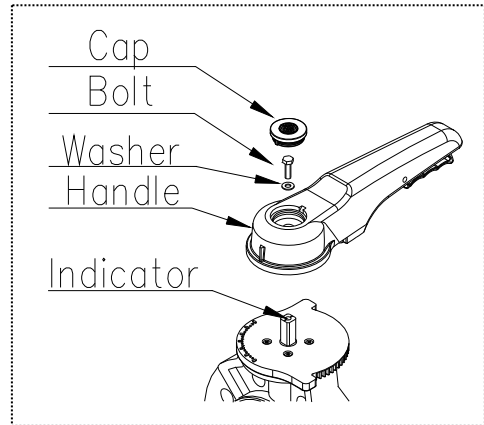



Nominal Size	40-100mm (1 1/2"-4")	125-200mm (5"-8")
Bolt Size	M6×15L	M8×15L
Socket Size	10	13

《Remove》

Procedure

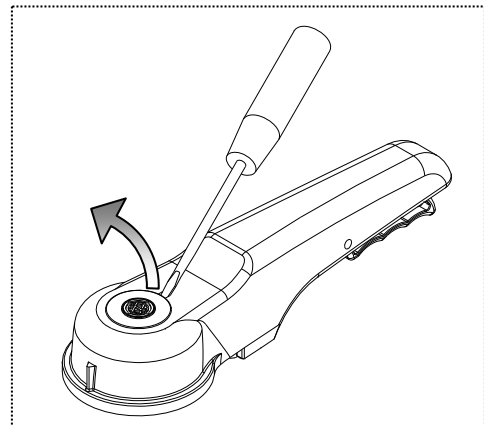
- 1) To remove the cap, push up the side of the cap by using screw driver (-).
- 2) Loose the bolts and washer by using socket wrench, then remove the handle.



  - Do not give any unjust force to cap, in installing or removing the cap. (It can be damaged)

Caution

(12) Adjustment procedure for adjuster on gear type

Necessary Items

- Safety Glove
- Allen Wrench
- Spanner Wrench

The adjustments for full-opened and full-shut position are step-less, and it can be done with the adjuster.

Adjustment for Full-shut (Full-opened) position

- 1) In Case of Gear Type
Remove the rubber cap of Full-closing (Full-opening) adjuster.
In Case of Top Gear Type
Loosen the rock nut of Full-Closing (Full-opening) adjuster.
- 2) Loosen the first adjuster hex-bolt completely by Allen wrench or spanner wrench.
- 3) Adjust the disc of valve to required position.
- 4) Tighten the adjuster hex-bolts.
- 5) In Case of Gear Type
Put the rubber cap of Full-closing (Full-opening) adjuster back on gearbox by hand.
In Case of Top Gear Type
Tighten the lock nut by spanner wrench.

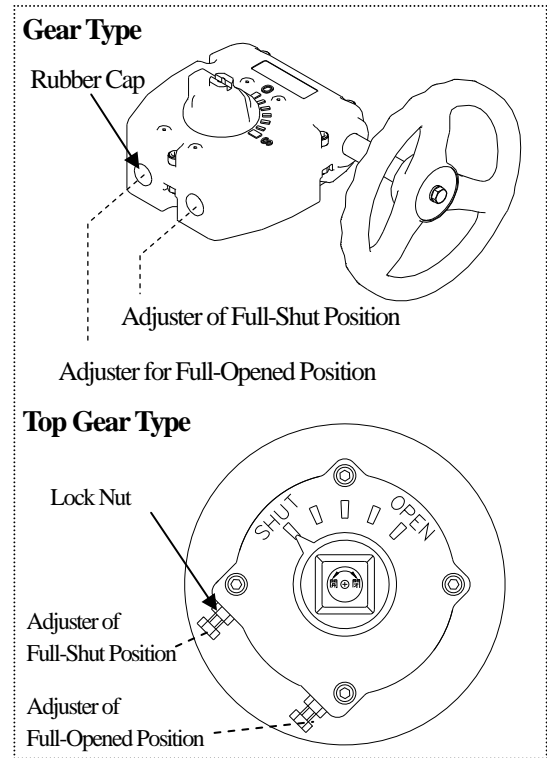

(13) Inspection items

- Perform periodic maintenance. (Leakage may develop due to temperature changes or over periods of prolonged storage, rest or operation.)



Inspect the following items.

(1)	Check for flaw, crack, or deformation on the valve.
(2)	Check for leaks to the outside.
(3)	Check for the deformation of seat due to improper installation of valve.
(4)	Check for the smoothness of handle operation..

(14) Troubleshooting

Phenomenon	Cause	Treatment
Fluid leaks from the valve even when the valve is fully closed.	1) The adjuster is not set correctly. 2) The seat is damaged or worn. 3) Foreign materials are caught. 4) The disc is damaged or worn. 5) The connecting bolts are over tightened or tightened unevenly.	Adjust the adjuster. Replace the seat. Clean it up. Replace the disc. Adjust and retighten.
Fluid leaks to the outside.	1) The seat is damaged or worn. 2) The connecting bolts are not tightened in proper torque or evenly.	Replace the seat. Adjust and retighten.
The handle does not work smoothly.	1) Foreign materials have adhered. 2) The gear box is damaged. 3) The connecting bolt is over tightened.	Clean it up. Repair or replace. Adjust and retighten.
Valve does not operate	1) The gear box is damaged 2) The stem is damaged.	Repair or replace. Replace the stem.

(15) Handling of Residual and Waste Materials



 - Make sure to consult a waste treatment dealer for recommendations on the proper disposal of plastic valves. (Poisonous gas is generated when the valve is burned improperly.)

Butterfly Valve

Type 57: 40-350mm (1 1/2"-14")

ASAHI YUKIZAI CORPORATION



Distributor

<http://www.asahi-yukizai.co.jp/en/>