

BUTTERFLY VALVE

Lever handle type

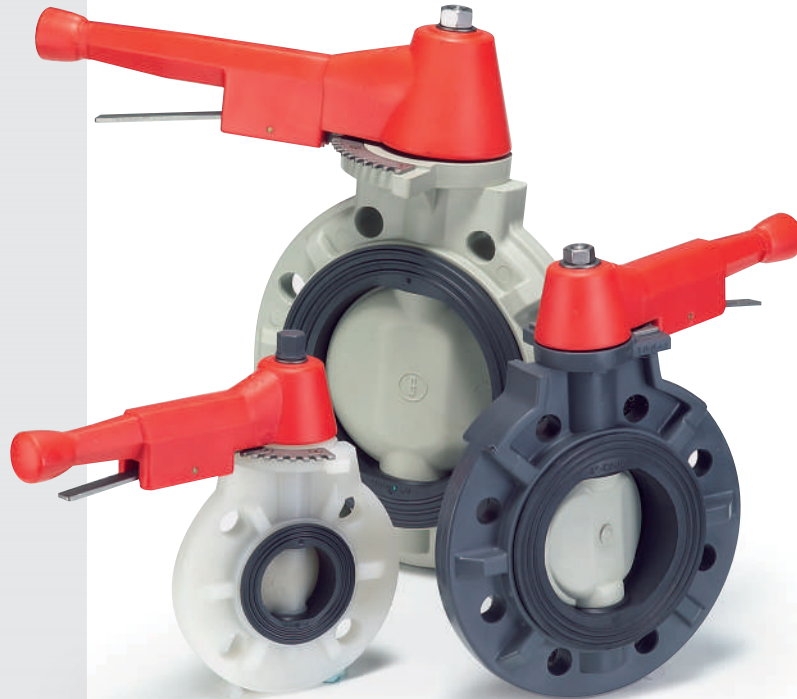

BB Series

BB300

Size: 2" - 8"

options: 8" (DN200) GEAR OPERATOR TYPE

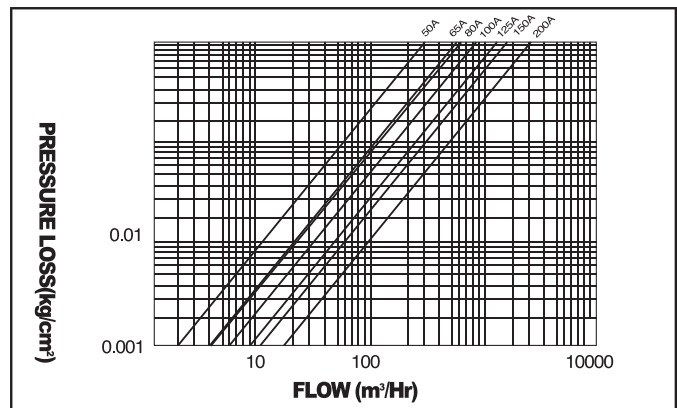
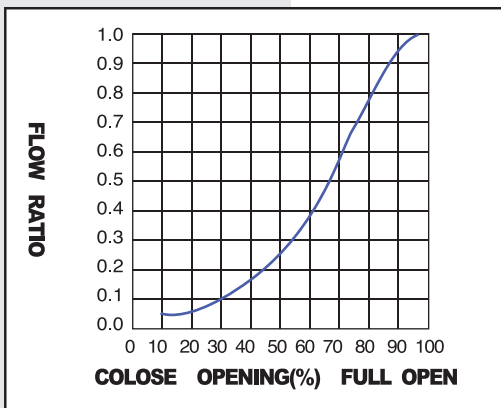

MATERIALS OF CONSTRUCTION

No.	Parts	Pcs.	Materials	No.	Parts	Pcs.	Materials
1	Body	1	UPVC,PP,PPG,PVDF,CPVC	10	Reatiner Cap	1	UPVC,PP,PVDF
2	Disc	1	UPVC,PP,PPG,PVDF,CPVC	11	Positioner	1	SUS304
3	Stem	1	SUS410,SUS316,SUS304	12	Screw	3...DN50-200 4...DN200	SUS304
4	Stem O-ring	2	EPDM,VITON	13	Handle	1	ABS
5	Washer	1	SUS304	14	Inserted Metal Of Handle	1	FC0208
6	Seat	1	EPDM,VITON,NBR, HYPALON	15	Nut	1	PVC COATED BRASS,SUS304
7	Disc O'ring(1)	2	EPDM,VITON	16	Handle Lever	1	SUS304
8	Disc O'ring(2)	2	EPDM,VITON	17	Spring	1	SUS304
9	Stem Retainer	1	SUS304	18	Set Pin	1	BSBM

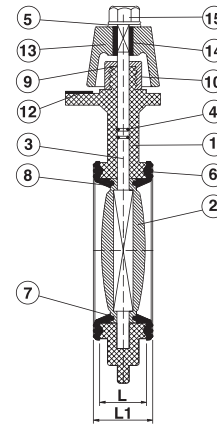
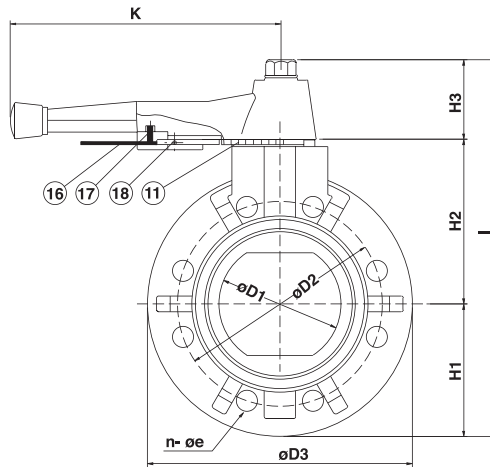

DN50~DN200

● TORQUE VALUES (1kgf/m=9.8N.m)

BF-V'S Size	Torque Under Without Any Water Pressure (Kgf/m)	Under Water Testing Pressure(Kg/cm ²)			BF-V'S Size	Torque Under Without Any Water Pressure (Kgf/m)	Under Water Testing Pressure(Kg/cm ²)		
		Water Pressure(Kg/cm ²)	Open Torque(Kgf/m)	Close Torque(Kgf/m)			Water Pressure(Kg/cm ²)	Open Torque(Kgf/m)	Close Torque(Kgf/m)
2"	1.5	15	0.5	0.5	10"	17.0	8	7	10
2-1/2"	1.5	15	0.5	0.5	12"	27.0	6	14	18
3"	2.0	15	1	1.5	14"	37.0	6	25	28
4"	2.0	12	1	1.5	16"	42.0	-	-	-
5"	5.0	12	2.5	4.5	18"	52.0	-	-	-
6"	6.5	12	4	7	20"	65.0	-	-	-
8"	10.0	10	6	8.5	24"	76.0	-	-	-

● DIMENSIONS TABLE

JIS														Unit: mm	
Nom. Size DN(inch)	D1	D2	D3	øe	n	L	L1	H1	H2	H3	I	K	Test Press (kgf/cm ²)		Working Press (kgf/cm ²)
													Body	Seat	
50(2")	57	120	165	19	4	36.5	40.5	82.5	102	63	253	220	15.0	12.0	10.0
65(2-1/2")	72	140	184	19	4	40.5	44.5	92	110	63	270	220	15.0	12.0	10.0
80(3")	80	150	200	19	8	40.5	44.5	100	118	63	286	220	15.0	12.0	10.0
100(4")	100	175	230	19	8	50.5	56.5	115	134	63	312	220	15.0	12.0	10.0
125(5")	130	210	256	23	8	60.5	66.5	128	160	96	391	310	15.0	12.0	10.0
150(6")	150	240	288	23	8	66	71	144	177	96	418	310	15.0	12.0	10.0
200(8")	203	290	348	23	12	82	87	174	204	93	476	414	15.0	12.0	10.0

ANSI														Unit: inch	
Nom. Size DN(inch)	D1	D2	D3	øe	n	L	L1	H1	H2	H3	I	K	Test Press (lb/in ²)		Working Press (lb/in ²)
													Body	Seat	
50(2")	2.24	4.75	6.50	0.75	4	1.44	1.59	3.25	4.01	2.48	9.96	8.66	235	180	150
65(2-1/2")	2.83	5.50	7.24	0.75	4	1.59	1.75	3.62	4.33	2.48	10.63	8.66	235	180	150
80(3")	3.15	6.00	7.87	0.75	4	1.59	1.75	3.94	4.64	2.48	11.26	8.66	235	180	150
100(4")	3.93	7.50	9.06	0.75	8	1.99	2.22	4.53	5.28	2.48	12.48	8.66	235	180	150
125(5")	5.12	8.50	10.07	0.87	8	2.38	2.62	5.00	6.30	3.78	15	12.20	235	180	150
150(6")	5.90	9.50	11.34	0.87	8	2.60	2.80	5.67	6.97	3.78	16.46	12.20	235	180	150
200(8")	7.99	11.75	13.70	0.87	8	3.23	3.43	6.85	8.03	3.66	18.74	16.30	235	180	150

DIN														Unit: mm	
Nom. Size DN(inch)	D1	D2	D3	øe	n	L	L1	H1	H2	H3	I	K	Test Press (bar)		Working Press (bar)
													Body	Seat	
50(2")	57	125	165	18	4	36.5	40.5	82.5	102	63	253	220	15.0	12.0	10.0
65(2-1/2")	72	145	184	18	4	40.5	44.5	92	110	63	270	220	15.0	12.0	10.0
80(3")	80	160	200	18	8	40.5	44.5	100	118	63	286	220	15.0	12.0	10.0
100(4")	100	180	230	18	8	50.5	56.5	115	134	63	312	220	15.0	12.0	10.0
125(5")	130	210	256	18	8	60.5	66.5	128	160	96	391	310	15.0	12.0	10.0
150(6")	150	240	288	23	8	66	71	144	177	96	418	310	15.0	12.0	10.0
200(8")	203	295	348	23	8	82	87	174	204	93	476	414	15.0	12.0	10.0

※ Standard dimensions based on PVC material.
 ※ The flanged length tolerance is according to EN558-1:1995.
 ※ L: The suggested length of the valve as installed on pipeline.